

Get Messy!

May–August 2013

Support material



Every effort has been made to trace and contact copyright owners for material used in this resource. We apologise for any inadvertent omissions or errors, and would ask those concerned to contact us so that full acknowledgment can be made in the future. Support material for use with *Get Messy! May–August 2013*.

Downloaded from www.messychurch.org.uk/resources/extra-resources

Published by BRF.

Invisible God – Helicopters

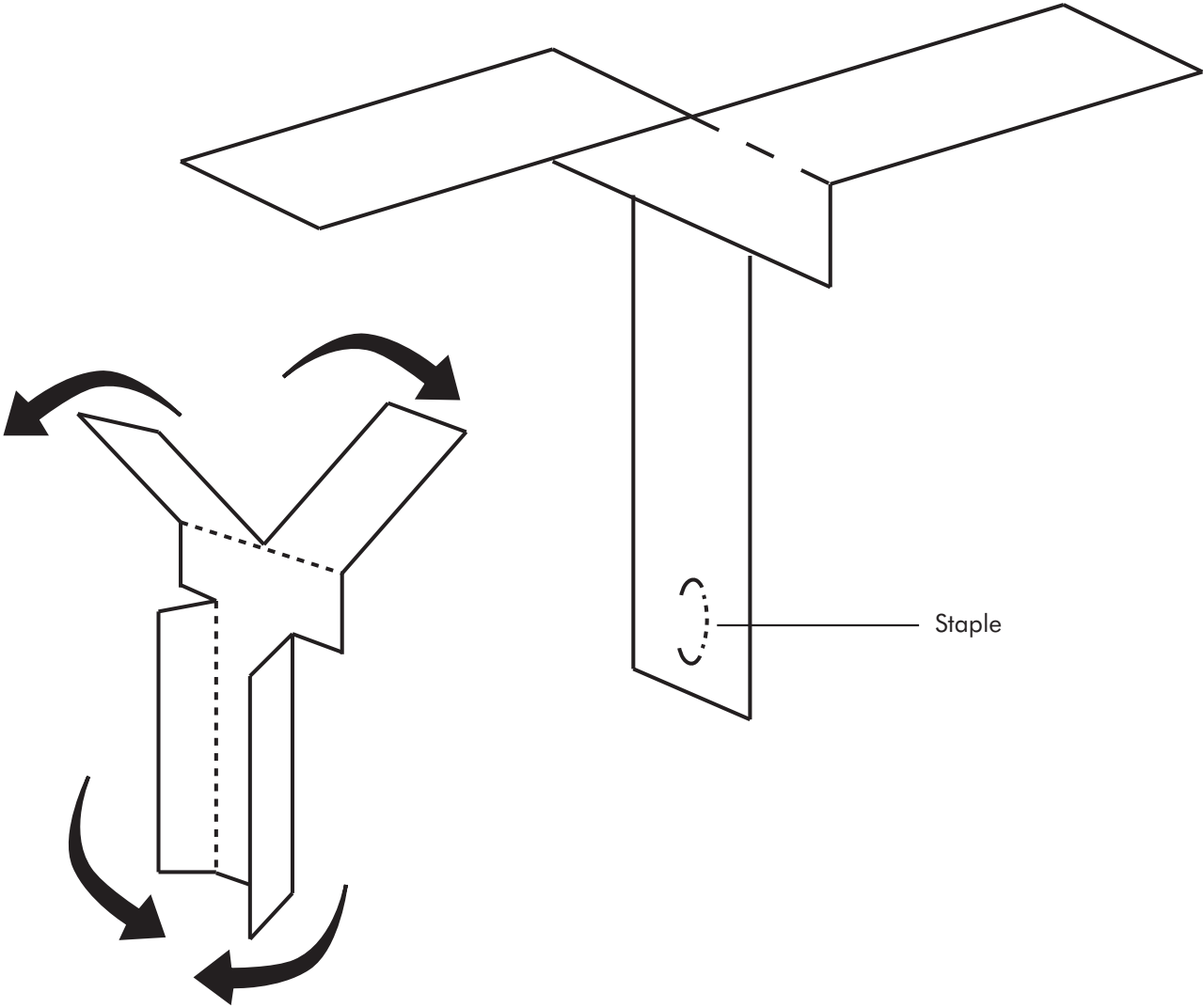
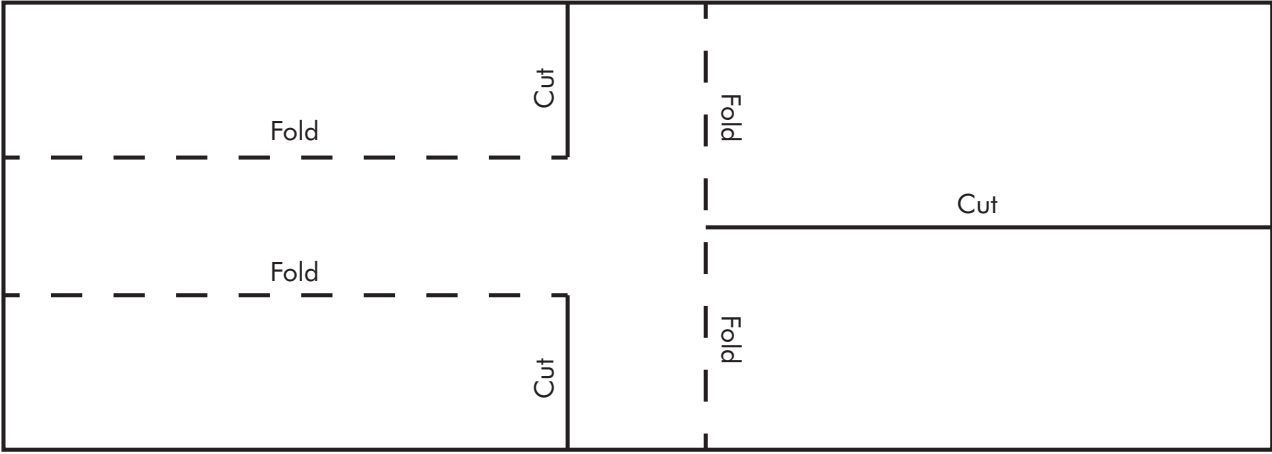

Mealtime cards

Invisible God

- If you have eaten your meal, does that mean it is invisible?
- Why do you think God likes to stay invisible?
- What would you do if you were invisible for a day?
- Some people prefer to listen to the radio rather than watch TV because they say the pictures are better (!). If you could see God, do you think he would look better than the way you imagine him?

Amy Carmichael

- Do you know anyone who has visited or lived in India?
- What do you like best about Amy's story?
- How can we listen to God?

Calming the storm

- Why do you think the disciples were scared, even though Jesus was right next to them?
- Do you think Jesus is really always with you?
- What do you do when you feel scared? Who do you turn to?
- How easy is it for you to trust God to look after you?

Zacchaeus

- When was the last time you were invited to a party?
- How many trees do you have in your garden and can you name them?
- Is there anybody here at Messy Church today that you haven't met before?
- When was the last time you invited someone to your house for tea or for a party?

Handout sheet – Invisible God

We are thinking about invisibility today, invisible forces, invisible effects and invisible substances. But most of all, we are thinking about the most powerful invisible being in and out of the universe—God.

What are we doing today?

1. Bubble painting—A bit of a blow
2. Bread making—Rise and shine
3. Helicopters—Watch them twirl
4. Balloon prayers—Up, up and away
5. Paper planes—Grand designing
6. Buzzer game—Steady as she goes
7. Invisible writing—Where did that come from?
8. Fishing magnet game—Attractive bait
9. Rainbow spinners—Where did that go?
10. Giant hoop bubbles—Rainbow sensations



Handout sheet – Amy Carmichael

Amy Carmichael spent most of her life in India, working to help children in need. Today's Messy Church is about her life. She believed God had a special plan for her life, and wanted her to tell other people about God's love for them.

What are we doing today?

1. Sari dressing up—Amy dressed in a sari to be like her Indian friends
2. Flower prayers—Make a paper flower and think about listening to God
3. Postcards to sponsored children—A special surprise for children in need
4. Bangles—Make a lovely Indian bangle
5. Junk model elephant—Work together to make the biggest and best elephant!
6. Icing fruit—Try creating some exotic fruit using icing
7. What do you see?—Look in the mirrors, read the verses and think about how God has made each of us different and special
8. Bird bath—Have a go at making a bird bath to take home
9. Big group collage—We can do more when we work together
10. What's special about me?—Make a picture of yourself, the person God made



Handout sheet – Calming the storm

Today we're looking at the story of Jesus in the boat with his disciples, and what it teaches us about having faith in difficult situations.

What are we doing today?

1. Storm in a teacup—The disciples' boat entered a storm that scared them
2. Marbled boats—Lots of things happen in life that can make us feel mixed up
3. Rain sticks—These remind us of the storm in the story
4. Edible boats—Jesus' power stopped the storm and kept the boat safe
5. 'Peace, be still' kit—A relaxation kit to help us to stop and be still
6. Moving boat picture—We can face rocky situations in life
7. Storm in a bottle—Create your own storm and then try to calm it down
8. Prayer station—A chance to pray about problems you may be having and ask for God's help
9. Boat race—See if you can keep your boat on course
10. Junk boats—Make a giant boat to help us tell the story



Handout sheet – Zacchaeus

Today we're looking at the story of Zacchaeus, friend of Jesus, and what it teaches us about how people can change.

What are we doing today?

1. Known by name—How are you different from other people?
2. Height charts—Do you ever find it difficult to see over a crowd?
3. Golden coin biscuits—Zacchaeus had become rich by collecting too much money from people
4. Binoculars—When we look through binoculars, we see things a little bit differently
5. Giant tree—Zacchaeus climbed to the top of a tree to get a clearer view of Jesus
6. Large crowd picture—What gets in the way of us seeing Jesus?
7. Table decoration—Today we remember the special meal that Jesus shared with Zacchaeus
8. Decorating stones—God calls us by name and wants us to follow him
9. Catapult a mini figure into a tree—How high up the tree will Zacchaeus reach?
10. Messy Church banner—The story of Zacchaeus is a story of love and forgiveness



Take-home ideas and Sunday treats

Invisible God

Take-home idea

Try making bread rolls together. Talk about the effect of the yeast, making the bread rise: we can't see it working, but we can see the rolls getting bigger. Jesus says that the kingdom of God is like a small amount of yeast that is mixed with a large amount of flour until it works all through the dough (Luke 13:21).

You will need: a mixing bowl; scales; teaspoon; wooden spoon; table spoon; cooling tray; measuring jug; 250g strong plain flour; 1 teaspoon salt; 1 teaspoon dried yeast; water; 1 tablespoon oil; cling film; paper plate

1. Put 4 tablespoons of boiling water into a measuring jug (a job for the adults). Add enough cold water to make it up to 150ml of lukewarm water.
2. Add the oil.
3. Put the flour in the mixing bowl and add the yeast and salt.
4. Stir the water into the flour and mix together.
5. Knead for 10 minutes until the dough is smooth.
6. Shape into six small bread rolls.
7. Leave the dough in a warm place to rise for around 1–1.5 hours.
8. Preheat the oven to 220°C/Gas 7 and grease a baking tray.
9. Bake in the oven for 10–15 minutes until the rolls are golden brown and sound hollow when tapped underneath.

Sunday treat

Invisible God, watch over us as we live our ordinary lives. We can't begin to understand how powerful and wonderful you are, but we can see all the beautiful things you have made and we can know what a glorious thing it is to live in the world you have created. Hold us close to you and let us feel your great love for us, all our lives.
Amen



Take-home ideas and Sunday treats

Amy Carmichael

Take-home idea

Amy said, 'You can give without loving, but you cannot love without giving.' As a family, is there someone you could give to? Maybe make some biscuits or a cake for someone who is ill.

Sunday treat

Make a flower shape. Talk together about what you want to pray for. Then in silence place the folded flower in a bowl of water. As it unfolds, spend some time in quiet together. You could use this prayer: Dear Lord, thank you that you know all about us, and what we need. Help us to trust you like Amy did. Amen



Take-home ideas and Sunday treats

Calming the storm

Take-home idea

Give Post-it™ notes to each member of the family. Write or draw a picture of something that you would like to do together as a family. Pick a time each week to have 'family rest time'. Pick out one of the Post-it™ notes and do the activity written or drawn on it.

Sunday treat

Lord Jesus, you know when I am happy, you know when I am sad, you know when I am good and you know when I am bad. You know when I am lonely and when I am afraid, you know when I am silly and the mistakes that I have made. I know sometimes I forget you are there and that you really love me. Help me to trust you at all times and safe in your arms I will be. Amen



Take-home ideas and Sunday treats

Zacchaeus

Take-home idea

Organise a picnic—invite a friend and their family. Think about people who are ‘in’ and people who are ‘left out’. Is there someone you could invite to your house for tea?

Sunday treat

Give each person a gold chocolate coin. As you hold the gold coin, say:

Lord Jesus, we thank you for your love for each one of us. Thank you that you know each of us by name. Thank you for... (*Name each person one at a time.*) We are sorry that we do not always show our love and care for each other as you would like us to. Please help us to be more like you each day. Amen



Session planning sheet

Date:

Theme:

Set-up time:

ACTIVITIES

Activity	Resources	Who will obtain resources?	Who will prepare?	Who will lead?
1.				
2.				
3.				
4.				
5.				
6.				
7.				
8.				
9.				
10.				

MENU

Ingredients/dish:	Who to buy/prepare:
Ingredients/dish:	Who to buy/prepare:
Ingredients/dish:	Who to buy/prepare:

CELEBRATION

